

HVI Publication 915  
2009 Rev. Edition  
1 March 2009

This edition supersedes all previous editions.

# HVI<sup>®</sup> LOUDNESS TESTING AND RATING PROCEDURE

This publication specifies prescriptively  
HVI's procedures for sound testing and  
loudness rating in sones in accordance  
with (ANSI) consensus standards.  
It applies to residential ventilating products.



Home Ventilating Institute<sup>®</sup>  
1000 North Rand Road, Suite 214  
Wauconda, IL 60084  
USA  
Phone: 847.526.2010

Fax: 847.526.2993  
e-mail: [cpd@hvi.org](mailto:cpd@hvi.org)  
Website: [www.hvi.org](http://www.hvi.org)

# HOME VENTILATING INSTITUTE®

## LOUDNESS TESTING AND RATING PROCEDURE

### **The History of HVI®**

The Home Ventilating Institute® (HVI®) was incorporated as a trade association in 1955. From the first, it has provided residential ventilating products information for members and consumers.

### **The History of HVI's Loudness Certification**

HVI initiated loudness testing and rating of ventilation products at the Texas Engineering Experiment Station (TEES) of Texas A & M University in 1970. From the beginning HVI has rated products in sones, based on one-third octave measurements in a diffuse reverberant chamber, using the comparison method in strict accordance with ANSI consensus standards. HVI-Certified loudness ratings are uniquely consistent because each certified product has been tested in the HVI-designated test laboratory, using the laboratory's calibrated reference sound source and the setup prescribed for the product category.

### **Disclaimer**

Final recourse for consumers, competitors, Members and any other entity seeking any remedy for product certification and/or performance disputes is with the involved parties, not with HVI.

### **Related HVI Publications**

- *HVI Publication 911: Certified Home Ventilating Products Directory ©*
- *HVI Publication 916: HVI Airflow Test Procedure ©*
- *HVI Publication 920: HVI Product Performance Certification Procedure Including Verification and Challenge ©*
- *HVI Publication 925: HVI Label and Logos Requirements ©*

## TABLE OF CONTENTS

1. Introduction .....	3
2. Definitions .....	5
3. Overview of HVI Loudness Testing and Rating Procedure .....	6
4. Equipment and Instrumentation .....	8
5. Test Procedure.....	12
6. Loudness Rating Symbols and Calculations .....	14
7. Test Report .....	16
8. Test Setups .....	17
9. Additional References .....	24
10. Special Test Situations.....	26
11. Appendix I. HVI LOUDNESS CALCULATIONS EXPLAINED .....	28
12. Appendix II. HVI EQUAL LOUDNESS INDEX TABLE .....	34
13. Appendix III. EXPLANATION AND DISCUSSION – HVI FAN LOUDNESS TESTING AND RATING .....	37

# HOME VENTILATING INSTITUTE ®

## LOUDNESS TESTING AND RATING PROCEDURE

### 1. Introduction

1.1. Basis. HVI Loudness Certification shall be based on ratings determined through testing, calculations, and procedures done in accordance with ANSI consensus standards. The fundamental standards are described below, and supporting standards are listed under Additional References, following in this procedure.

1.1.1.1. Shorthand for standards named in this procedure appears in curly brackets { }. For the full reference, see below and Additional References, in Section 9 of this publication.

1.1.1.2. Standards marked with an asterisk (\*) are available for review at HVI Headquarters.

1.1.2. *ANSI S12.51-2002 ISO 3741:1999. American National Standard: Acoustics – Determination of sound power levels of noise sources using sound pressure – Precision method for reverberation rooms.* Standard includes Corrigendum 1-2001. Published by the Acoustical Society of America, Melville, NY.\*

1.1.3. *ANSI-AMCA 300-05, Reverberant Room Method for Sound Testing of Fans,* published by the Air Movement and Control Association, International, Inc., of Arlington Heights, IL. (Although ASA/ANSI calls it the comparison method, and AMCA calls it the substitution method, the standards are in general agreement.)\*

1.1.4. *ANSI S3.4-1980 (R 2003). American National Standard: Procedure for the Computation of Loudness of Noise,* published by the Acoustical Society of America, Melville, NY.\*

1.2. Purpose. The purpose of this procedure is to rigidly prescribe methods of measuring and rating loudness of residential ventilating equipment in preparation for HVI Certification.

1.2.1. This procedure prescribes uniform testing, calculating, and rating procedures strictly governed by the consensus standards listed above.

1.2.2. As a manual for uniform laboratory procedures and calculations, this publication provides the foundation for the strength of the HVI Sound Certification program.

- 1.2.3. Uniform sound testing and loudness rating is necessary for consistent HVI-Certified ratings.
  - 1.2.4. The outstanding consistency of HVI-Certified ratings allows the loudness of one ventilating product to be compared to that of another.
  - 1.2.5. HVI-Certified sound ratings are a single number loudness rating, enabling consumers to compare one HVI-Certified product to another in terms of expected loudness when operating in a home.
  - 1.2.6. The magnitude of difference between product ratings makes comparison intuitive for consumers because the HVI loudness rating uses the sone, the most widely used and accepted linear loudness rating method.
  - 1.2.7. This publication is intended for laboratory testing and cannot be used for field testing.
  - 1.2.8. To maintain rigorous consistency and comparability of HVI loudness ratings, it is necessary that this publication be exceptionally specific and that it be reliably followed.
  - 1.2.9. This publication also provides useful information to assist members with their own sound measurement facilities, and to prepare products for submittal to an HVI-designated laboratory.
- 1.3. Scope. This procedure describes loudness testing and rating requirements prescribed by HVI before certification of each of its defined categories of catalogued powered residential ventilation equipment. It identifies those parts of ANSI consensus standards that HVI authorizes for loudness rating by establishing testing procedures based on those parts. In the interest of consistent ratings, this publication limits the options found in those standards.
    - 1.3.1. This procedure describes HVI's requirements for measuring fan sound power in 24 one-third octave bands with center frequencies from 50 to 10,000 hertz (ANSI bands numbered 17-40).
    - 1.3.2. The procedure describes HVI's requirements for converting the test data into a single rating number in sones in accordance with Mark VI sones, originally defined by Dr. S. S. Stevens and maintained by the Acoustic Society of America as ANSI S3.4.

1.3.3. HVI certification procedures are for residential ventilating products. Non-residential products may be more appropriately rated and certified by other procedures, especially those that certify a wide range of tabulated data for design engineers who combine several components and calculate the expected sound a complete system may develop in a room or building.

1.4. Relationship with other HVI publications. Before a ventilation product is tested for loudness under this procedure, it is tested for airflow in accordance with *HVI Publication 916: HVI Airflow Test Procedure*©. Using the test reports produced for both airflow and sound testing, product rating and certification are done in accordance with *HVI Publication 920: HVI Product Performance Certification Procedure Including Verification and Challenge*©. When HVI-Certified products are offered in the marketplace, the HVI Certification Label and other HVI Marks must be used in accordance with *HVI 925: HVI Label and Logos Requirements*©.

## 2. Definitions

2.1. reserved

2.2. reserved

2.3. Decibel. The decibel (dB) is a unit for comparing one value with another. Since it is logarithmic, it is particularly useful for comparing values with a large range of magnitude. Because it is comparative, the reference value must be identified. Decibels are used to measure many quantities including sound power, sound pressure, sound intensity, and power; therefore it is necessary to label the dB (e.g., dB re  $P_0$ , dB re  $W_0$ ).

2.4. Sound Power Level. A sound power level,  $L_w$ , is mathematically defined as 10 times the common logarithm of the ratio of a given sound power,  $W$ , in watts, to the reference sound power,  $W_0$ .

$$L_w = 10 \text{Log} \left( \frac{W}{W_0} \right)$$

The reference sound power ( $W_0$ ) has been established as 1 picowatt ( $1 \text{ pW} = 10^{-12} \text{ W}$ ). Thus, the decibel unit is properly shown with its reference (dB re  $W_0$ ).

Sound power is the quantity of power a device converts to sound. It may be thought of as the “strength” of a source for producing sound, without consideration for distance or environment. (Sound measurements for product rating are in sound pressure because methods of measuring sound power are not practical for the types of products covered.)

- 2.5. Sound pressure level. The sound pressure level,  $L_p$ , is mathematically defined as 10 times the common logarithm of the square of the ratio of the sound pressure produced by a sound source,  $P$ , to the referenced sound pressure,  $P_0$ .

$$L_p = 10 \text{Log} \left( \frac{P}{P_0} \right)^2$$

The relationship may also be stated as 20 times the common logarithm of the ratio of a given sound pressure to the reference sound pressure.

$$L_p = 20 \text{Log} \left( \frac{P}{P_0} \right)$$

The reference sound pressure has been established as 20 micropascals ( $\mu\text{Pa}$ ), which is the accepted threshold of human hearing. Since measurements are made in one-third-octave bands, the term one-third-octave band sound pressure level is used in this procedure. Sound pressure results when a source of sound power radiates sound some distance through some environment. The pressure magnitude of sound waves traveling through air can be readily measured using standard methods and it is affected by the distance and the environment.

- 2.6. Spherical free field. A theoretical sound dispersal pattern where sound travels outward from a source in all directions (spherical), and is free from interference or reflections. The condition HVI has selected for uniform presentation of certified loudness data is the spherical free field. The selection is arbitrary and HVI explains it was chosen, in part, because certified products including their ducts are tested entirely inside the sound chamber where sound radiated from all directions is measured.

### 3. Overview of HVI Loudness Testing and Rating Procedure

- 3.1. This brief overview is provided for an introductory understanding of the HVI sound testing, loudness rating, and certification process.
- 3.1.1. This description uses some shorthand (e.g., RSS for reference sound source, FAN for the product being tested, and BGD for background). See also Symbols, Section 6.1 of this publication.
- 3.2. For HVI certification, a test unit is first airflow tested in the HVI-designated laboratory as per *HVI Publication 916*©, then promptly sound-tested without modification.
- 3.3. All HVI-Certified products are sound-tested in a prescribed diffuse, reverberation chamber, using the same reference sound source (RSS), measuring equipment, test setup, and low background sound.

- 3.3.1. Exception: Effective August 1, 2009, HVI requires a six microphone array to be used for the testing of products which are to be certified at less than 1.5 sones. Products which are to be certified at 1.5 sones or greater may be tested using a rotating boom microphone though HVI does not recommend this. Refer to Section 4.4 of this publication for additional information.
- 3.4. Four sound pressure measurements, in 24 one-third-octave bands, are conducted.
  - 3.4.1. First, the test fan plus the background (FAN+BGD) is measured with the test unit operating and the RSS off. BGD will be subtracted.
  - 3.4.2. Second, the background (BGD) is measured with both the test unit and RSS off.
  - 3.4.3. Third, the reference sound source plus the background (RSS+BGD) is measured with the RSS operating and the test unit off. BGD is subtracted.
  - 3.4.4. Fourth, the background (BGD) is measured with both the test unit and RSS off. This measurement is only used for checking background steadiness.
- 3.5. Sound power of the test unit is determined by mathematically comparing sound pressure measurements in the chamber to sound pressure measurements of the RSS, using its sound power calibration data.
- 3.6. Sound pressure is calculated, based on the tested sound power at the standard rating distance and environment. Work to this point uses decibels (sound power) and decibels (sound pressure).
- 3.7. Sound pressure data are converted to ANSI human response data based on the equal loudness indices of ANSI S3.4, for each frequency band.
- 3.8. Equal loudness indices are combined into a single rating number, weighted for human dominant tone sensitivity, yielding a single fan loudness number in sones.
- 3.9. The member applies to HVI for product certification based on the single number sones rating. If the application is found to be in order, HVI issues HVI certification and the newly rated product appears in *HVI Publication 911: Certified Home Ventilating Products Directory*®.
- 3.10. HVI-Certified products are included in HVI's annual verification program, and are subject to HVI's member challenge program, both described in *HVI Publication 920*®.

## 4. Equipment and Instrumentation

- 4.1. Sound tests shall be conducted in a laboratory grade diffuse reverberation chamber constructed with heavy, multi-layered, insulated, non-parallel, reasonably airtight walls with hard (reverberant) surfaces.
  - 4.1.1. The HVI sound test chamber is nominally 25 feet (7.6 m) long, 20 feet (6.1) wide, 12 feet (3.7 m) high, with a volume of 6000 cubic feet (170 m<sup>3</sup>), as a building inside a building. The chamber is as described in {ANSI S12.51}.
  - 4.1.2. The chamber shall be qualified, including for low sound level testing. Acceptance of chamber qualification shall be by the General Membership of HVI, as proposed by the HVI Engineering Committee, normally based on analysis by the HVI Sound Committee.
    - 4.1.2.1. Qualification criteria shall include consideration of standing wave intensity, pure tone response, background noise level, laboratory integrity, procedure, personnel proficiency, and other criteria considered significant to the objectives of HVI certification.
    - 4.1.2.2. Qualification may include 'round robin' testing.
  - 4.1.3. The chamber may be equipped with baffles as required to minimize three-dimensional standing waves.
  - 4.1.4. The chamber shall be supplied with makeup air through an insulated labyrinthine inlet duct with a throttling device. The duct is sufficiently large to provide makeup air for most tests.
    - 4.1.4.1. A quiet, adjustable speed air supply blower shall be available at the air inlet to be used when required for testing fans with greater airflow. To avoid introducing sound into the background, use of the air supply blower should be limited. See Test Procedure, following.
  - 4.1.5. The chamber air outlet shall be through an expendable panel with close fitting test duct openings, through a rectangular isolation duct, into the anechoic muffler.
  - 4.1.6. The chamber shall be on a resilient base minimizing transmission of ground-borne (sound) vibration.
  - 4.1.7. The chamber's single personnel entry shall be equipped with two doors with seals and rigidly closing latches.

- 4.2. The anechoic muffler shall be a cube approximately 8 feet per side, connected to the test chamber by a rectangular isolation duct. The path from the test chamber to the anechoic muffler outlet shall be air tight. The outlet of the muffler shall be into the atmosphere, avoiding entry of environmental sound. The outlet shall have provision for throttling airflow.
- 4.2.1. For some tests, a test duct runs from inside the chamber straight through the anechoic muffler, discharging to the environment. In that case a panel with a close fitting duct opening shall cover the muffler outlet.
- 4.3. The microphones shall be random incident microphones having a linear free field response and shall conform to {ANSI S1.15/1}. In general, larger diameter microphones are more sensitive to low sound pressure.
- 4.4. An array of six microphones shall be used for all tests except where noted below. They shall be located at fixed locations within the chamber established by the multiple-microphone qualification process described in {ANSI S12.51}. The locations shall be documented in three dimensions.
- 4.4.1. Measurements from all microphones in the array shall be mixed and averaged by an analyzer that meets appropriate ANSI requirements. The measurement thus processed shall be the measured sound pressure.
- 4.4.2. Effective August 1, 2009, HVI mandates that all ventilation products which are to be certified at less than 1.5 sones must be tested using an array of six microphones.
- 4.4.2.1. No retesting of products certified prior to August 1, 2009 is required.
- 4.4.3. HVI recommends that all ventilation products which are to be certified at 1.5 sones or greater be tested using an array of six microphones; however, these products may be tested using a rotating boom microphone at the manufacturer's discretion.
- 4.4.3.1. If a rotating boom microphone is used, the microphone shall be mounted on a rotating boom 60 to 75 inches long, capable of moving the microphone through 165 to 180 degrees during the timed (30-second) data collection period. The boom path shall be tilted 45 degrees. The boom may rotate 360 degrees.
- 4.4.4. Effective August, 1, 2009, all products will be verified using an array of six microphones, even if originally certified using a rotating boom microphone.

- 4.4.4.1. Exception: HVI Headquarters may choose to conduct verification testing using a rotating boom microphone for products which are certified at 1.5 sones or greater if the lab(s) employing the six microphone array method are unable to handle testing volume.
- 4.5. The control for starting and stopping the data measurement period shall be outside the chamber.
- 4.6. The location of the six microphones shall be exactly the same in all three dimensions for every test.
- 4.6.1. Where a rotating boom is used, the location of the microphone's measurement arc shall be exactly the same in all three dimensions for every test.
- 4.7. Microphone accessories such as cable and pre-amplifier shall be qualified and conform to {ANSI S1.15/1}.
- 4.8. The sound analyzer outside the chamber shall be capable of real-time capture and averaging, and shall conform to {ANSI S1.4}.
- 4.8.1. Digital filters shall divide the data into 24 one-third-octave bands with center frequencies from 50 hertz to 10,000 hertz (ANSI bands numbered 17 through 40) and shall conform to {ANSI S1.11}.
- 4.9. The output of the sound analyzer shall be electronically fed directly into a computer program to calculate the single number rating described below.
- 4.10. The instrument group shall be capable of printing test report data.
- 4.11. There shall be a source of regulated or controlled voltage available for the test subject and the reference sound source.
- 4.12. There shall be individually switched electrical receptacles for the test subject and the reference sound source inside the chamber. The switches shall be located outside the chamber.
- 4.13. There shall be a digital tachometer sensor inside the chamber, connected to a display outside the chamber.

4.14. Diagram of typical chamber (depicts both rotating boom and six microphone array).

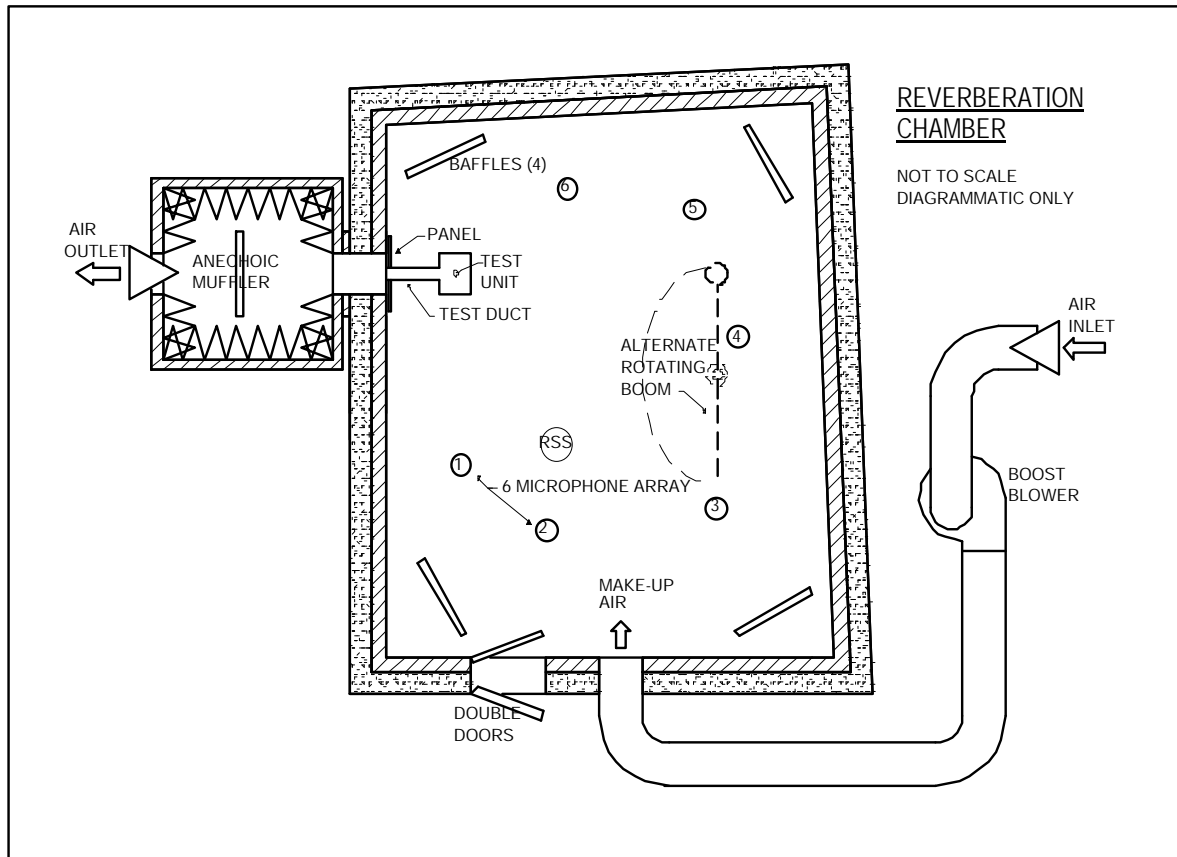

4.15. The reference sound source shall be an accepted laboratory device consisting of a special-purpose direct-drive centrifugal fan with a synchronous motor. Its performance and calibration shall conform to {ANSI S12.5}.

4.15.1. The RSS shall produce steady broadband sound over the frequency range from 100 to 10,000 hertz, free from discrete frequency components. The one-third-octave band sound power levels shall be within 12 decibels over the range from 100 to 10,000 hertz and the sound power levels in adjacent one-third octave bands shall not vary by more than  $\pm 3$  dB.

4.15.2. The RSS shall be in the same location for every test. The location shall be established as part of chamber qualification.

4.15.3. The reference sound source shall be calibrated annually by a recognized acoustical test laboratory, which will provide RSS sound power data in 24 one-third-octave bands.

## 5. Test Procedure

- 5.1. The sound test shall be conducted as soon as practical after the air test, carefully moving the same test unit to the sound chamber without modification.
- 5.2. The test unit shall be firmly mounted in the chamber on stable test stands as shown in the Test Setup section that follows.
  - 5.2.1. The supporting surface of the test stands will be padded where they contact the test fixture.
- 5.3. The test duct shall be run from the test unit through the chamber just through the panel, directing fan air to flow through the isolation duct into the anechoic muffler, from which it exits to the environment.
  - 5.3.1. The panel is expendable, has a duct-size opening, and the duct is tightly sealed to it for the test.
- 5.4. The test unit motor shall be warmed up by operating 30 minutes minimum, or until input power is stable at normal value, whichever is longer, before testing.
- 5.5. All duct connections and any leaks in the setup shall be taped to avoid air leakage.
- 5.6. The test setup and duct shall be inspected to be sure there are no rattles or loose contacts.
- 5.7. Referring to the airflow test data, the sound test shall be conducted at the airflow test input voltage, and with the airflow at the static pressure rating point.
  - 5.7.1. HVI's nominal test voltage shall be 120 volts, 60 hertz unless the test unit is rated for higher voltage or different frequency.
  - 5.7.2. The airflow shall be controlled by the static pressure, adjusting the inlet and/or the discharge air. Airflow and static pressure are considered properly adjusted when the fan motor speed is within 0.5 percent of the speed recorded for the rated static pressure during the airflow test. Fan speed shall be stable before taking sound measurements.
- 5.8. Measurements shall be averaged by the sound analyzer over a period of 30 seconds.
- 5.9. Measurements shall be taken while no unusual sounds exist in the area of the test chamber.

- 5.9.1. No lights or any other noise source shall be operating inside the chamber.
- 5.10. Four measurement sequences are taken for each test in the sequence described below. Each measurement shall be sound pressure in *dB re P<sub>0</sub>*, taken in 24 one-third-octave bands with center frequencies from 50 to 10,000 hertz. All four measurements shall be taken in prompt succession to maximize background sound steadiness.
- 5.10.1. The first measurement shall be conducted with the test unit operating and the RSS off. These data are the fan plus background sound pressure measurement,  $L_{pfm} + L_{pbm}$ .
- 5.10.2. The second measurement shall be of the background sound pressure level, with both the RSS and the test unit off. These data are background sound pressure measurement,  $L_{pbm}$ .
- 5.10.3. The third measurement shall be with the RSS operating and the test unit off. These data are the RSS plus background sound pressure measurement,  $L_{prm} + L_{pbm}$ .
- 5.10.4. The fourth measurement shall be of the background sound pressure level, with both the RSS and the test unit off, the same as the second measurement. These data are background sound pressure steadiness check,  $L_{pbck}$ .
- 5.10.4.1. Note: If the makeup air blower is required to be running for the fan test, it must be running for all tests.
- 5.11. The background shall be qualified as being sufficiently steady for effective sound measurement by arithmetically subtracting the background,  $L_{pbm}$ , from the background steadiness check,  $L_{pbck}$ .
- 5.11.1. If the difference between the two background measurements exceeds the limits established for any band, the background is not sufficiently steady for the test. Limits for most bands are 1 decibel or less, but may be larger for the lowest bands.
- 5.11.1.1. Limits are set by agreement between the designated laboratory and the HVI Sound Committee and are retained on record at HVI Headquarters.
- 5.12. The background shall be qualified as being sufficiently quiet for effective sound measurement by arithmetically subtracting the background,  $L_{pbm}$ , from the fan plus background,  $L_{pfm} + L_{pbm}$ .

5.13. The background is further qualified by subtracting background,  $L_{pbm}$ , arithmetically from the RSS and background,  $L_{prm} + L_{pbm}$ .

5.13.1. If the arithmetic subtraction finds the background (BGD) to be separated by less than 6 dB from either the RSS+BGD or the FAN+BGD, the background sound level must be reduced and the test re-run.

5.13.2. If all efforts to reduce the background are unsuccessful, including testing at a quieter time of day, the test shall be examined by the member and the laboratory, who may agree to proceed. The test report shall be footnoted to indicate which of the one-third-octave bands lack 6 dB separation. The test report may be accepted for certification if HVI agrees, as per *HVI Publication 920*©, that all is in order.

5.14. After all four measurements have been completed, and the background qualification calculation indicates the background is sufficiently quiet, the remainder of the test procedure consists of the calculations described below.

## 6. Loudness Rating Symbols and Calculations

### 6.1. Symbols

SYMBOL	EXPLANATION	SHORTHAND	UNITS
$L$	Sound		
$L_p$	Sound pressure		dB re $P_0$
$L_w$	Sound power		dB re $W_0$
$L_{pbm}$	Sound pressure, background, measured	BGD	dB re $P_0$
$L_{prm}$	Sound pressure, RSS & backgrnd., measured	RSS+BGD	dB re $P_0$
$L_{pfm}$	Sound pressure, fan & backgrnd., measured	FAN+BGD	dB re $P_0$
$L_{pr}$	Sound pressure, calculated, RSS	RSS	dB re $P_0$
$L_{pf}$	Sound pressure, calculated, fan	FAN	dB re $P_0$
$L_{wr}$	Sound power, calibrated, RSS	CAL	dB re $W_0$
$L_{wf}$	Sound power, calculated, fan	WF	dB re $W_0$
$RCR$	Room characteristic ratio	RCR	dimensionless
$K_{rd}$	Rating distance constant (14.65 for HVI)	K	dB re $W_0$
$S$	Tabulated band loudness index	s	sones
$S$	Weighted single number loudness rating	S	Sones

### 6.2. Calculations

6.2.1. Calculations shall be as specified by HVI.

6.2.1.1. A compact disc (CD), with calculations in Microsoft Excel and equal loudness band indices, available from HVI Headquarters, meets this requirement.

6.2.1.2. Examples of the spreadsheet and disc information may be found in Appendices I and II.

6.2.1.3. A practical calculation example may be found in an Appendix I.

6.2.2. Calculations shall be performed, in all 24 bands, using all of the digits available at each stage, with no intermediate rounding.

6.2.3. At the end of the calculations, the resulting some value shall be presented in the test report with at least three decimals. Rounding of the rating, if any, shall be as described in *HVI Publication 920*©.

6.2.4. This Calculation Section assumes the background has been checked for steadiness and quietness, both of which are described in Test Procedure, Section 5, preceding.

6.2.5. To find fan sound pressure,  $L_{pf}$ , logarithmically subtract measured background sound pressure,  $L_{pbm}$ , from measured sound pressure of FAN + BGD,  $L_{pfm}$ .

$$L_{pf} = 10 \text{Log}_{10} \left( 10^{L_{pfm}/10} - 10^{L_{pbm}/10} \right)$$

6.2.5.1. Actual values shall be used in the calculation.  $L_{pf}$  shall never be negative; in the unlikely event that  $L_{pfm}$  measures less than  $L_{pbm}$ ,  $L_{pf}$  shall be taken as zero.

6.2.6. To find RSS sound pressure,  $L_{pr}$ , logarithmically subtract measured background sound pressure level,  $L_{pbm}$ , from measured sound pressure level of RSS + BGD,  $L_{prm}$ .

$$L_{pr} = 10 \text{Log}_{10} \left( 10^{L_{prm}/10} - 10^{L_{pbm}/10} \right)$$

6.2.7. To find room characteristic ratio,  $RCR$ , arithmetically subtract RSS sound pressure,  $L_{pr}$ , from RSS sound power calibration,  $L_{wr}$ . (Note: Arithmetic subtraction results in division;  $RCR$  is the ratio of RSS sound power divided by RSS sound pressure.)

$$RCR = L_{wr} - L_{pr} \text{ (arithmetically)}$$

6.2.8. To find fan sound power,  $L_{wf}$ , arithmetically add room characteristic ratio,  $L_{rcr}$ , to fan sound pressure,  $L_{pf}$ . (Note: Arithmetically adding the ratio results in multiplying it times fan sound pressure.)

$$L_{wf} = L_{pf} + RCR \text{ (arithmetically)}$$

6.2.9. To find fan sound pressure for the presentation distance and environment in each band,  $L_{pf}'$ , arithmetically subtract the presentation distance factor,  $K_{rd}$ , from the fan sound power,  $L_{wf}'$ . All HVI rating is at the same presentation factor, 14.65, which represents the sound pressure produced by a sound power source at a distance of 5 feet (1.524 meters) in a spherical free field.

$$L_{pf}' = L_{wf}' - K_{rd}$$

6.2.10. To find the equal loudness index for each band,  $s$ , refer the HVI equal loudness index table, which is part of the HVI sound test CD. It is also shown in Appendix II of this Procedure.

6.2.10.1. Usually the dB quantities used to look up equal loudness indices are not whole numbers and straight-line interpolation shall be used.

6.2.11. To combine the 24 one-third-octave band loudness values,  $s$ , into a single sone value,  $S$ , with the required weighting for human response to dominant tones, sum as follows.

$$S = 0.85s_{\max} + 0.15(s_1 + s_2 + s_3 + s_4 + s_5 + \dots + s_{22} + s_{23} + s_{24})$$

6.2.12. The sone value is presented in three decimals in the test report. HVI certification requires rounding as described in *HVI Publication 920*©.

## 7. Test Report

7.1. HVI sound testing and loudness rating is required to be conducted in conjunction with HVI airflow testing.

7.2. The test report for loudness testing shall accompany the applicable airflow test report.

7.3. The loudness test report shall include the following information.

7.3.1. The test setup shall be documented by recording setup number, description, and by photography.

7.3.2. All measured data shall be tabulated.

7.3.3. All calculations shall be tabulated.

7.3.4. The calculated single number loudness rating in sones shall be presented.

7.3.5. The test report shall provide the number of decimals for all values as indicated in the HVI Calculation Spreadsheet.

7.3.6. The test report shall indicate which testing method was employed (rotating boom microphone or six microphone array).

## 8. Test Setups

8.1. Each setup shall be as shown in the following setup figures, shall simulate as nearly as practical actual field installation, and shall be in accordance with the manufacturer's installation instructions for the product.

8.1.1. All sound test setups utilize firm tubular steel stands of adjustable height.

8.1.2. The member requesting the sound test may furnish the test fixture, including the panel for fans and the frame for hoods.

8.1.3. The panel and the frame required for HVI sound testing are also intended to be used to support the product for airflow testing, thereby minimizing the potential for product modification between airflow and sound testing.

8.2. The purpose of HVI sound testing is to produce ratings that are comparable and repeatable. Therefore, the lab shall make every attempt to set up similar products identically, and to repeat the setup in future tests, including HVI Verification and HVI Challenge.

8.3. Test duct and fittings shall be as per manufacturer's instructions and as expected to be used in actual installation. Length of horizontal test duct terminating at the panel shall be between 20 and 30 inches.

8.4. Test duct shall be galvanized steel, nominally 26 gauge.

8.4.1. Exception: Where expressly prescribed in a test setup, or prescribed in member's instructions, duct and fittings of other construction may be used.

8.5. HVI sound testing under this procedure follows airflow testing, procedures for which are found in *HVI Publication 916*®. Requirements in *HVI Publication 916*®, especially those related to requiring that all components be shipped together, accessories, and the like, also apply to this procedure. Since requirements for airflow testing must be met before sound testing, not all requirements are repeated in this procedure.

8.6. In the event that there are questions about a setup not anticipated in this procedure, the laboratory shall contact the member and HVI Headquarters for agreement in the decisions made.

8.6.1. Decisions made shall be described for future use, and addressed by HVI, so that similar products shall be tested as near identically as possible.

8.7. reserved

8.8. reserved

8.9. All HVI Standard Product Categories are listed in *HVI Publication 920*©. Those with sound certification programs are listed below with the applicable sound test setup.

HVI STANDARD PRODUCT CATEGORY	TEST SETUP NUMBER
Bathroom exhaust fans including combination units	1, 2, 3
Downdraft kitchen exhausters (incl. non-powered)	7
Inline fans	8
Kitchen exhaust fans	1, 2, 3
Kitchen range hoods (incl. non-powered)	4, 5
Other room exhaust fans	1, 2, 3
Remote exterior mounted ventilators	8
Interior kitchen power units	7, 4, 5
Heat/energy recovery ventilator (two-duct wall/ceiling insert only)	1

8.9.1. HVI certifies inline fans and remote exterior mounted ventilators for sound only if they are offered to the marketplace for kitchen ventilation, in which case they may be combination rated for airflow and each combination individually rated for sound.

8.9.2. HVI certifies interior kitchen power units for airflow and sound only in conjunction with a non-powered kitchen ventilator.

8.9.3. HVI certifies only two-duct ceiling/wall insert HRV and ERV products for airflow and sound in conjunction with a CSA C439 test for energy. Test Setup 1 shall be used with the exception that two ducts will penetrate the anechoic chamber, with the intake air duct continued into the laboratory.

8.10. The following sound test setup diagrams cover most products. Test stands and fixtures described below applicable setups are omitted for clarity.

8.10.1. Setup No. 1 below, shows a ceiling fan with horizontal discharge. Height is established by running the test duct horizontal from the panel.

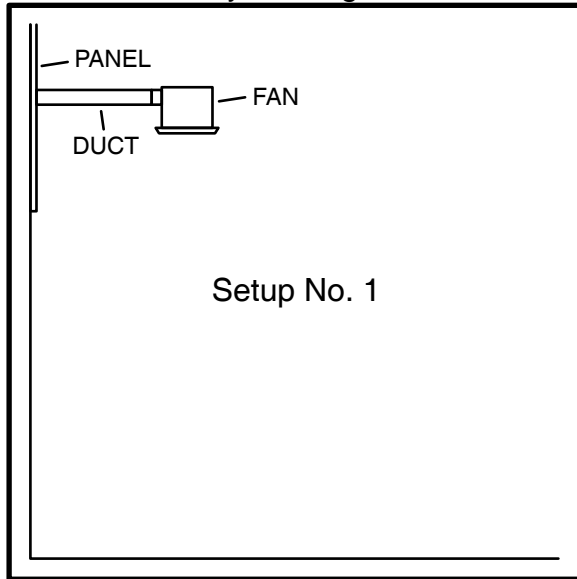

8.10.2. Setup No. 2, below, shows a ceiling fan with vertical discharge. Height is established by the vertical portion of the duct, which is 2.5 to 4 diameters long between test unit and elbow.

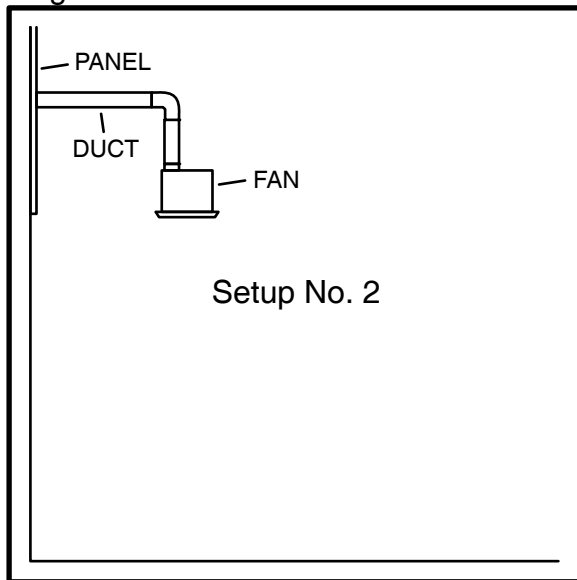

8.10.2.1. Test fixture 2a, below, simulates a fan installed in a ceiling. For a larger fan, the 2x4's may be 22.5 inches on center. The fan is mounted with the bottom edge of the fan flush with the 'interior' surface, unless member's instructions specify otherwise. Test stands, padded at contact points, support both sides of the fixture at right angles to the joists. Fan opening is centered for a fan on mounting bars, adjacent to joist for fans with mounting tabs.

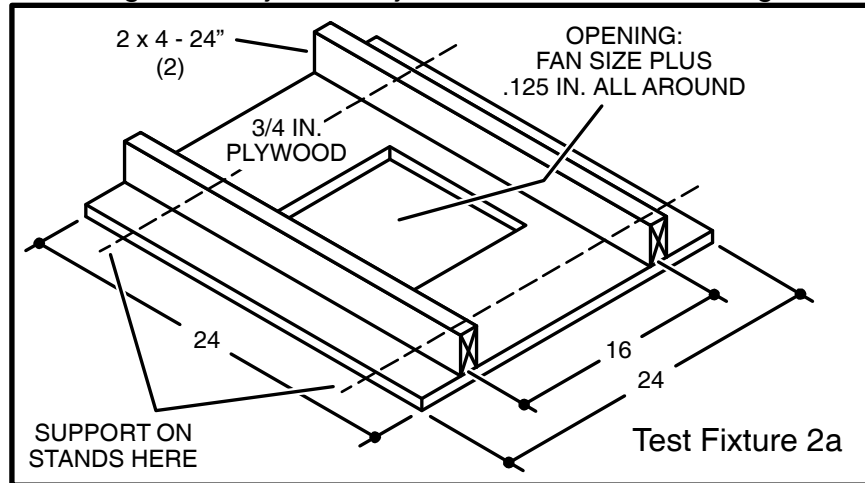

8.10.3. Setup No. 3, below, shows a wall fan with vertical discharge. The vertical duct is 2.5 to 4 diameters long between the test unit and elbow, which establishes the height of the test fan.

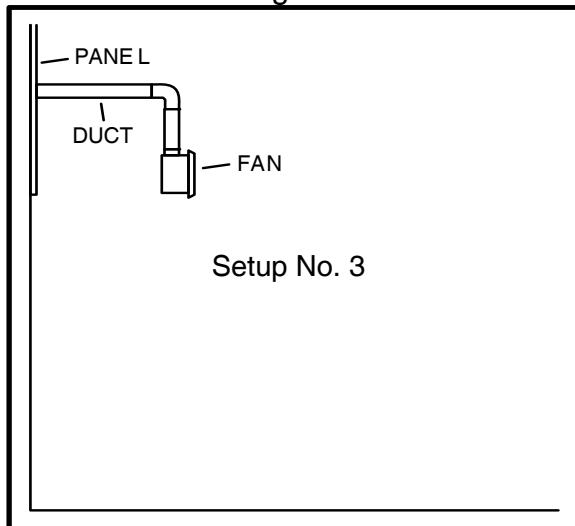

8.10.3.1. Test fixture 3a, below, is for a ducted wall fan. It is the same as test fixture 2a, with two 2x4's added so it can be supported on test stands as a vertical panel simulating a wall.

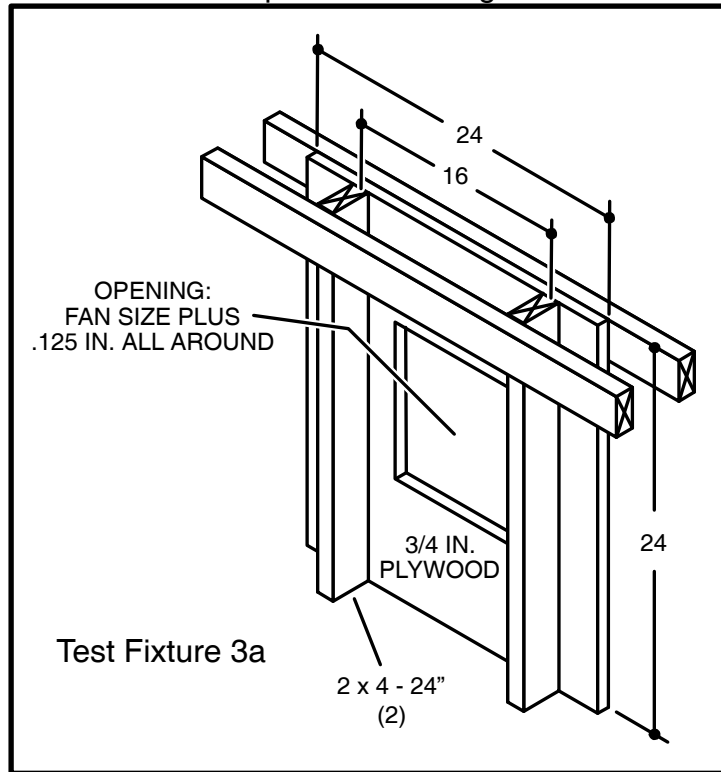

8.10.4. Setup No. 4, below, shows a range hood with horizontal discharge. The hood bottom is 60 inches above the floor, simulating normal installation.

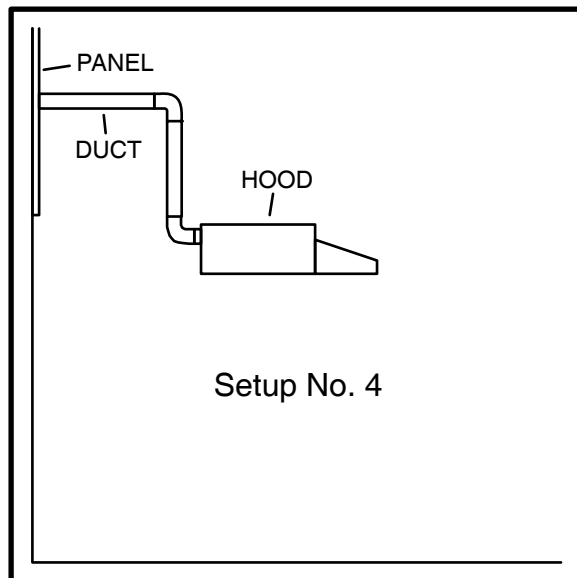

8.10.5. Setup No. 5, below, shows a range hood with vertical discharge. The bottom of the hood is 60 inches above the floor, simulating a normal installation, which determines the length of the vertical duct.

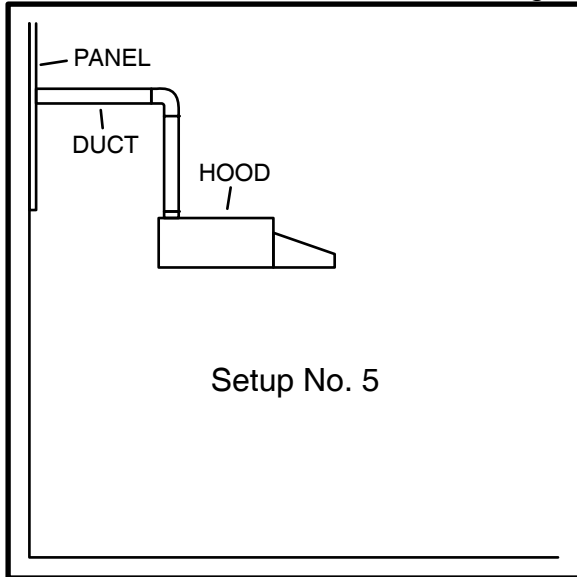

8.10.5.1. Test fixture 5a, below, provides solid support for range hood testing. It is constructed of 2x4's 12 inches longer than hood width, spaced from 11 to 16 inches apart, with shorter 2x4's front to back to which the hood is mounted. Shorter pieces may also protrude beyond longer ones.

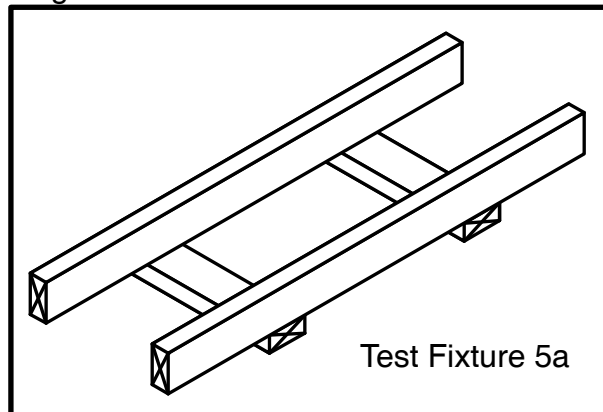

8.10.6. Setup No. 6, below, shows a through-wall fan, which has no duct connection. It is mounted directly to the center of the panel in the chamber wall.

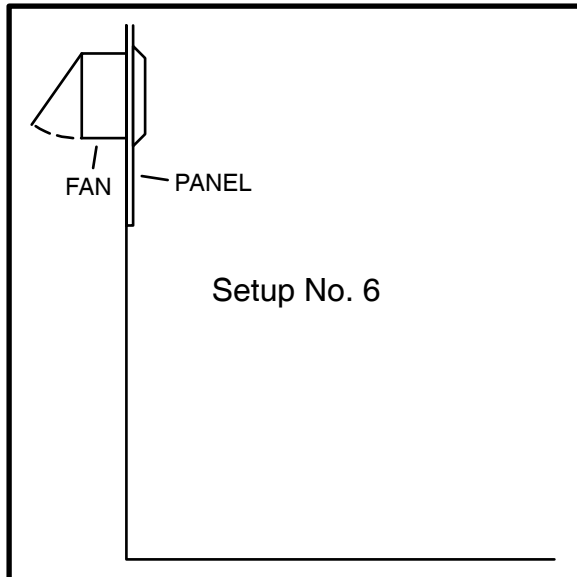

8.10.7. Setup No. 7, below, shows a downdraft kitchen exhauster. The variety of downdraft configurations makes it impractical to specify a standard test fixture. A stiff framework to hold the test unit not lower than the standard 36 inch countertop height shall be used for each sound test, unless the duct arrangement makes a greater height necessary, in which case the duct shall be near the floor but not touching.

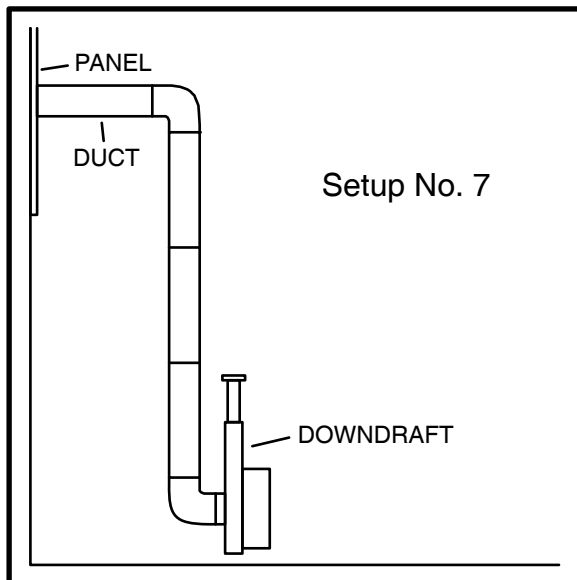

8.10.8. Setup No. 8, below, shows a non-powered kitchen exhauster in the sound chamber, connected to an in-line fan or a remote exterior mounted ventilator just outside the anechoic chamber. Duct sizes shall be the same for each; if they are not, the transition used for the airflow test shall be installed the same way for the sound test. Two close-fitting duct panels shall be used: one at the normal position inside the chamber, the other at the air outlet of the anechoic muffler.

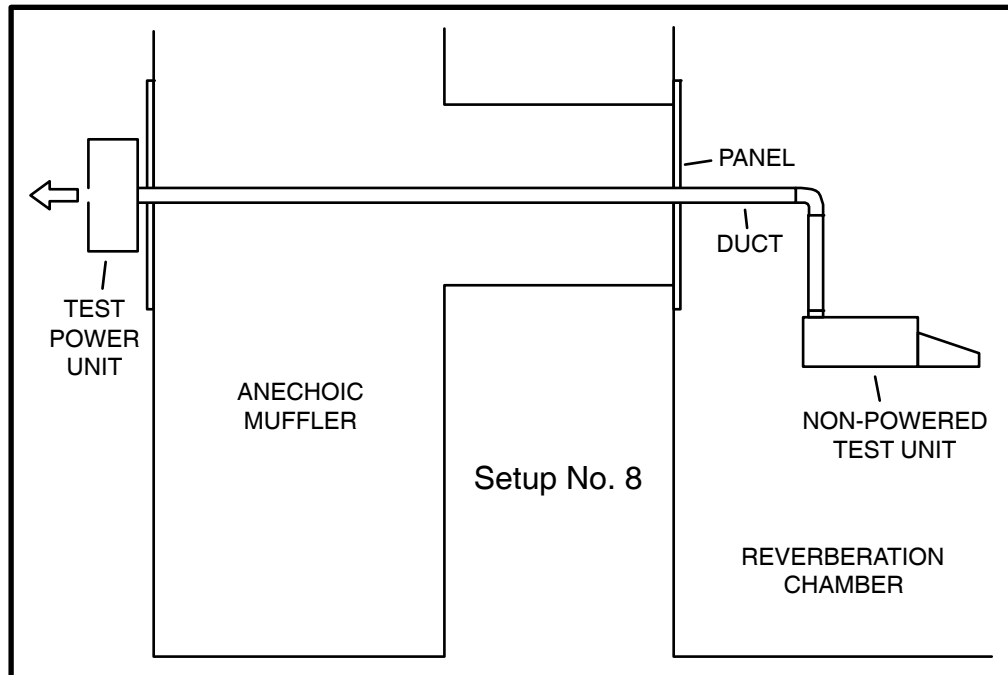

## 9. Additional References

9.1. Basic references for this procedure are at the beginning under "Basis" for clarity. The following references are also related to the HVI Certification program, and/or provide additional information.

9.1.1. Standards named in this procedure appear in curly brackets { } as shorthand. For the full reference, see below, and Basis.

9.1.2. Asterisks (\*) indicate references normally retained by HVI.

9.2. *ANSI S1.1-1994 (R 2004)*. American National Standard: Acoustical Terminology.\*

9.3. *ANSI S1.4-1983 (R 2001)*. American National Standard: Specification for Sound Level Meters. This standard includes ANSI S1.4A-1985 (R 2001) Amendment to ANSI S1.4 1983.

- 9.4. *ANSI S1.6-1984 (R 2001)*. American National Standard: Preferred Frequencies, Frequency Levels, and Band Numbers for Acoustical Measurements.
- 9.5. *ANSI S1.10-1966 (R 2001)*. American National Standard: Method for the Calibration of Microphones.
- 9.6. *ANSI S1.11-2004*. American National Standard: Specification for Octave-Band and Fractional-Octave-Band Analog and Digital Filters.
- 9.7. *ANSI S1.15-1997/Part 1 (R 2001)*. American National Standard: Measurement Microphones, Part 1: Specifications for Laboratory Standard Microphones.
- 9.8. *ANSI S12.5-1990 (R 1997)*. American National Standard: Requirements for the Performance and Calibration of Reference Sound Sources.
- 9.9. *ANSI-AMCA 301-05, Methods for Calculating Fan Sound Ratings from Laboratory Test Data*, published by the Air Movement and Control Association, International, Inc., of Arlington Heights, IL. (Calculations specified in AMCA 301 for conditions with less than 6 dB are not in agreement with this procedure.)\*
- 9.9.1. Although conversion of ratings from a test subject to other sizes and configurations is described in AMCA 301, HVI certification requires testing the model to be certified and does not permit mathematical conversion to other fan sizes or configurations.
- 9.10. Clapp, D. and C. E. Neeley, *A Program for Rating the Loudness of Consumer Fan Products*, Noise control Engineering, Vol. 11, No. 1, 1978.\*
- 9.11. *HVI Publication 916: HVI Airflow Test Procedure*, published by the Home Ventilating Institute, Wauconda, IL.\*
- 9.12. Stevens, S. S., *Procedure for Calculating Loudness: Mark VI*, The Journal of the Acoustical Society of America, Vol. 33, No. 11, November 1961.\*
- 9.13. Wolbrink, D. W., Gary Crow, John Harper, and Tony Schrank, *Thirty Years Experience . . . and 100 Million HVI Certification Labels*; paper presented to Acoustical Society of America 14 October 1998, as HVI's response to a request from ASA.\*

## 10. Special Test Situations

- 10.1. This section describes special situations and procedures not covered completely by the preceding descriptions.
- 10.1.1. Range hood working speed testing provides an optional opportunity for a member to obtain a second HVI rating at “working speed”, for range hoods with multiple speeds.
- 10.1.1.1. The procedure relies upon a second airflow test at or above 100 cfm assuming the same duct system as the basic HVI rating, which is required to be at maximum speed. Details are found in *HVI Publication 916*©.
- 10.1.1.2. The sound test follows the airflow test as soon as possible and utilizes parameters established in the airflow test.
- 10.1.1.3. When sound testing a range hood for working speed, the maximum speed sound test is conducted first. Then the speed of the range hood is set to the working speed setting and another sound measurement is taken.
- 10.1.1.3.1. The working speed setting is verified by reading the voltage at the range hood motor, leaving sound room makeup air settings as established in the maximum speed sound test. Since there is inherently less stability at working speed, rpm shall be monitored, but is not subject to the same tight tolerance.
- 10.1.1.4. The test report shall provide the same information as for a normal test, and is expected to be a combined test report of all conditions tested.
- 10.1.2. Combination testing for kitchen ventilation provides an opportunity for rating kitchen power units of several types and non-powered kitchen ventilating devices of several types by a combination method.
- 10.1.2.1. Combination testing is described in detail in *HVI Publication 916*© and *HVI Publication 920*©. In summary, *HVI Publication 916*© describes airflow tests for non-powered hoods and non-powered downdraft ventilators as “systems”, and tests for remote exterior ventilators, interior power packs, and inline fans as “fans”. The airflow rating point is based on the crossing of the system and fan curve, providing both are tested with the same duct size. See *HVI Publication 916*© for details.

- 10.1.2.2. Sound rating cannot be similarly accomplished by crossing test report curves. Therefore, each separate combination must be tested for sound together.
- 10.1.2.3. Non-powered kitchen ventilators with internal kitchen power units are tested for sound using the same setup as is used for conventional range hoods. Each combination must be tested.
- 10.1.2.4. Non-powered kitchen ventilators with exterior kitchen power units and/or inline fans are tested with the ventilator in the sound chamber and the exterior ventilator and/or inline fan just outside the anechoic muffler. The two are connected with a galvanized duct of the same size as was used for the airflow test.
- 10.1.2.4.1. The HVI required rating is as described. Optionally, an additional rating may be obtained with an acoustic muffler in the connecting duct.
- 10.1.2.4.2. Ratings based on tests with a muffler shall be accompanied by a footnote explaining that a muffler was used, and shall identify it by model number.
- 10.1.3. Testing of two-duct ceiling/wall insert HRV and ERV products is the same as ceiling insert fans except that there are two ducts that exit the reverberant room. The discharge of the unit is run into the anechoic chamber, while the intake duct is run through the anechoic chamber and terminates in the laboratory with an adjustable damper used to set the pressure at the test pressure of 0.1 inches of static pressure.

## APPENDIX I. HVI LOUDNESS CALCULATIONS EXPLAINED

This appendix provides a step-by-step explanation of the HVI sound test calculation procedure, using the HVI sone calculation spreadsheet program. The numbers in the example are contrived, and are only an example to help understand the HVI sound calculation process as described in the body of this publication. Familiarity with the calculations can help analyze fan performance. Only part of the spreadsheet is shown because of space available.

Following the explanation, an image of the HVI sone calculation spreadsheet follows for reference. Finally, the formulae used in that spreadsheet are shown.

This appendix is informational only. For laboratory usage, the latest HVI sone calculation spreadsheet CD should be used. It is available from HVI Headquarters.

### **STEP 1.** Enter RSS calibration data in line 10.

10	$L_{wr}$	RSS CAL Calibration Data (Given)	76.66	71.77	73.87	75.50	75.56	75.41	75.60	76.17	76.50
----	----------	----------------------------------	-------	-------	-------	-------	-------	-------	-------	-------	-------

Reference Sound Source calibration data is the sound power level of the reference sound source being used for the tests. Calibration data is determined by a designated qualified independent testing laboratory through (annual) calibration.

### **STEP 2.** Enter the four laboratory sound pressure measurements in lines 1-4.

		<i>Enter Test Measurements:</i>									
1	$L_{pfm}$	Meas. FAN+BGD	24.79	40.07	29.45	38.76	50.14	33.56	40.4	41.13	37.28
2	$L_{pbm}$	Meas. BGD	24.04	38.23	29.54	19.99	24.55	26.5	35.63	36.99	29.87
3	$L_{prm}$	Meas. RSS+BGD	67.59	70.25	61.69	63.92	66.77	65.26	64.72	65.31	66.2
4	$L_{pbck}$	Meas. BGD for check	25	38.57	29.73	20.6	24.74	26.46	35.68	36.76	29.73

First, with fan running in the chamber, sound pressure of FAN+BGD is measured. Next, with nothing operating in the chamber, sound pressure of BGD is measured. Third, with reference sound source running in the chamber, sound pressure of RSS+BGD is measured. Finally, with nothing operating in the chamber, sound pressure of BGD is measured once again. Measurements must be taken within the shortest possible time span. Measurement data are transferred to the calculation spreadsheet electronically. The first BGD measurement is used for all sound calculations.

### **STEP 3.** Check for steady background and background separation, lines 5-7.

		<i>Check Background Steadiness and Level:</i>									
5		2-4, Arith. Steady BGD?	OK	OK	OK	OK	OK	OK	OK	OK	OK
6		3-2, Arithmetically. Separation?	43.550	32.020	32.150	43.930	42.220	38.760	29.090	28.320	36.330
7		1-2, Arithmetically. Separation?	0.750	1.840	-0.090	18.770	25.590	7.060	4.770	4.140	7.410
<i>Bands with &lt;6db background separation:</i>			<u>50</u>	<u>63</u>	<u>80</u>	-	-	-	<u>200</u>	<u>250</u>	-

This is a laboratory calculation to qualify the background for this test. Line 5 compares the two background measurements (lines 2 and 4) for steadiness; if difference is not less than Limits for BGD steadiness 'NoTest' is entered. (Limits for BGD steadiness are listed near the top.) Line 6 and 7 check to ensure BGD is 6 dB less than RSS+BGD and FAN+BGD; if either is less than 6 dB the frequency of the non-complying band is entered.

**STEP 4.** Find actual FAN sound pressure and RSS sound pressure in lines 8 and 9.

		<b>Subtract Background measurement:</b>									
8	$L_{pr}$	Log 3-2 (RSS+BGD)-BGD=RSS	67.590	70.247	61.687	63.920	66.770	65.259	64.715	65.304	66.199
9	$L_{pf}$	Log 1-2 (FAN+BGD)-BGD=FAN	16.793	35.453	0.000	38.702	50.128	32.608	38.638	39.015	36.410

BGD sound pressure is subtracted from measured RSS+BGD and FAN+BGD, yielding the measured sound pressure for each. These two calculations are logarithmic because sound pressure measurements are in decibels, which are logarithmic.

**STEP 5.** Find room characteristic ratio, RCR, in line 11.

		<b>Calculate Room Characteristic Ratio and 1/3-Oct. Fan Sound Power:</b>									
10	$L_{wr}$	RSS CAL Calibration Data (Given)	76.66	71.77	73.87	75.50	75.56	75.41	75.60	76.17	76.50
11	$L_{rcr}$	Arith. 10-8 (RSS pow-pres=RCR)	9.070	1.523	12.183	11.580	8.790	10.151	10.885	10.866	10.301

The room characteristic ratio is found by subtracting arithmetically the measured RSS sound pressure from the calibrated RSS sound power previously entered. The result is the dimensionless room characteristic ratio. The RCR represents the character of way the diffuse reverberation chamber reacts to the sound power of the RSS. It is properly termed a ratio because subtracting logarithms results in division—a ratio.

**STEP 6.** Find fan sound power by applying the RCR to fan pressure in line 12.

		<b>Calculate Room Characteristic Ratio and 1/3-Oct. Fan Sound Power:</b>									
10	$L_{wr}$	RSS CAL Calibration Data (Given)	76.66	71.77	73.87	75.50	75.56	75.41	75.60	76.17	76.50
11	$L_{rcr}$	Arith. 10-8 (RSS pow-pres=RCR)	9.070	1.523	12.183	11.580	8.790	10.151	10.885	10.866	10.301
12	$L_{wf}$	Arith. 9+11 (FAN pres+RCR=pow)	25.863	36.975	12.183	50.282	58.918	42.759	49.524	49.882	46.711

The same RCR, ratio of the RSS measured sound pressure to the RSS calibrated sound power, is added arithmetically to the fan measured sound pressure, in effect multiplying it by the RCR. That converts measured FAN sound pressure to FAN sound power in each band.

**STEP 7.** Find fan sound pressure at presentation conditions in lines 14 and 15.

		<b>Fan Pressure at Std Distance, in Std Environment:</b>									
14	$K_{rd}$	Given, dB down @ 5 feet	-14.65	-14.65	-14.65	-14.65	-14.65	-14.65	-14.65	-14.65	-14.65
15	$L_p$	Arith. 13-14 (Fan Test Results)	11.213	22.325	0.000	35.632	44.268	28.109	34.874	35.232	32.061

Having found the FAN sound power, next the sound pressure that will be produced by that sound power under certain conditions is determined. The standard HVI sound presentation conditions are 5 feet from the fan, in a spherical free field, taken as a constant, 14.65. The result is the sound pressure the fan will produce at that distance.

**STEP 8.** Find the equal loudness index, *s*, in sones, for all 24 bands, line 16.

		<b>Convert to single Sones Rating Number:</b>									
16	s	Lookup sones for each band	0.000	0.000	0.000	0.052	0.639	0.000	0.304	0.444	0.374

The HVI sone calculation spreadsheet automatically looks up the equal loudness index for each band, accessing the HVI equal loudness index table attached to the spreadsheet. The equal loudness index of each band reflects human response to the loudness of a sound at that frequency. Straight-line interpolation is used to resolve fractional values between the whole number dB sound pressure values in the table.

**STEP 9.** Find the single sones rating number by calculating in line 17.

		<b>Convert to single Sones Rating Number:</b>										
16	s	Lookup sones for each band	0.000	0.000	0.000	0.052	0.639	0.000	0.304	0.444	0.374	
17	S	Add sones & weight for <b>HVI Sone Rating:</b>										<b>2.758</b>

This is the single-number HVI sone loudness rating. The calculation provides weighting for the dominant frequency band in accordance with human response.

**SUMMARY.** The preceding, reviewed with reference to the sample spreadsheet that follows, the equations that follow, and HVI equal loudness index table, provides an understanding of the calculation process.

Page 1 of the HVI Sone Calculation Spreadsheet

Example for explanation.		HVI Sones Calculation Spreadsheet - 24-Band										Autodate: 23-Feb-06					
Test Note	Line No.	Symbol	ANSI 1/3-Octave Band No.	17	18	19	20	21	22	23	24	25	26	27	28		
		Columns	Hertz	50	63	80	100	125	160	200	250	315	400	500	630		
		Limits for BGD Steadiness		2	4	2	2	2	1	1	1	1	1	1	1		
		<b>Enter Test Measurements:</b>															
	1	L <sub>pfm</sub>	Meas. FAN+BGD	24.79	40.07	29.45	38.76	50.14	33.56	40.4	41.13	37.28	41.42	44.9	43.72		
	2	L <sub>pbn</sub>	Meas. BGD	24.04	38.23	29.54	19.99	24.55	26.5	35.63	36.99	29.87	23.64	17.4	17.29		
	3	L <sub>pim</sub>	Meas. RSS+BGD	67.59	70.25	61.69	63.92	66.77	65.26	64.72	65.31	66.2	69.03	71.17	72.2		
	4	L <sub>pbc</sub>	Meas. BGD for check	25	38.57	29.73	20.6	24.74	26.46	35.68	36.76	29.73	23.73	17.5	17.59		
		<b>Check Background Steadiness and Level:</b>															
	5		2-4, Arith. Steady BGD?	OK	OK	OK	OK	OK	OK	OK	OK	OK	OK	OK	OK		
	6		3-2, Arithmetically. Separation?	43.550	32.020	32.150	43.930	42.220	38.760	29.090	28.320	36.330	45.390	53.770	54.910		
	7		1-2, Arithmetically. Separation?	0.750	1.840	-0.090	18.770	25.590	7.060	4.770	4.140	7.410	17.780	27.500	26.430		
		<b>Bands with &lt;6db background separation:</b>															
				50	63	80				200	250						
		<b>Subtract Background measurement:</b>															
	8	L <sub>pr</sub>	Log 3-2 (RSS+BGD)-BGD=RSS	67.590	70.247	61.687	63.920	66.770	65.259	64.715	65.304	66.199	69.030	71.170	72.200		
	9	L <sub>pf</sub>	Log 1-2 (FAN+BGD)-BGD=FAN	16.793	35.453	0.000	38.702	50.128	32.608	38.638	39.015	36.410	41.347	44.892	43.710		
		<b>Calculate Room Characteristic Ratio and 1/3-Oct. Fan Sound Power:</b>															
	10	L <sub>wr</sub>	RSS CAL Calibration Data (Given)	76.66	71.77	73.87	75.50	75.56	75.41	75.60	76.17	76.50	76.97	76.90	76.33		
	11	L <sub>rcr</sub>	Arith. 10-8 (RSS pow-pres=RCR)	9.070	1.523	12.183	11.580	8.790	10.151	10.885	10.866	10.301	7.940	5.730	4.130		
	12	L <sub>wf</sub>	Arith. 9+11 (FAN pres+RCR=pow)	25.863	36.975	12.183	50.282	58.918	42.759	49.524	49.882	46.711	49.287	50.622	47.840		
		<b>Fan Pressure at Std Distance, in Std Environment:</b>															
	14	K <sub>rd</sub>	Given, dB down @ 5 feet	-14.65	-14.65	-14.65	-14.65	-14.65	-14.65	-14.65	-14.65	-14.65	-14.65	-14.65	-14.65		
	15	L <sub>p'</sub>	Arith. 13-14 (Fan Test Results)	11.213	22.325	0.000	35.632	44.268	28.109	34.874	35.232	32.061	34.637	35.972	33.190		
		<b>Convert to single Sones Rating Number:</b>															
	16	S	Lookup sones for each band	0.000	0.000	0.000	0.052	0.639	0.000	0.304	0.444	0.374	0.665	0.868	0.743		
	17	S	Add sones & weight for HVI Sone Rating:													2.758	

(Reference: Lookup table ref. column number.)

Test Note		Page 2													Comments:			
Example for explanation.																		
Line No.	Symbol	Column	ANSI 1/3-Octave Band No.	29	30	31	32	33	34	35	36	37	38	39	40			
			Hertz	800	1,000	1,250	1,600	2,000	2,500	3,150	4,000	5,000	6,300	8,000	10,000			
			Limits for BGD Steadiness	2	0.5	0.5	0.5	0.5	0.5	0.5	0.5	0.5	0.5	0.5	0.5			
<b>Enter Test Measurements:</b>																		
1	$L_{p(m)}$		Meas. FAN+BGD	48.14	44.68	43.44	39.67	39.04	35.91	33.89	32.03	28.1	22.98	18.11	12.68			
2	$L_{p(bm)}$		Meas. BGD	13.12	9.45	5.97	3.62	3.08	3.06	3.25	4.09	4.68	5.6	6.11	6.04			
3	$L_{p(m)}$		Meas. RSS+BGD	72.29	72.08	72.13	71.99	71.12	69.59	68.27	67.31	66.3	65.14	62.79	57.08			
4	$L_{p(bck)}$		Meas. BGD for check	13.05	9.45	6.21	3.93	3.25	3.08	3.25	4.14	4.73	5.6	6.14	6.04			
<b>Check Background Steadiness and Level:</b>																		
5			2-4, Arith. Steady BGD?	OK	OK	OK	OK	OK	OK	OK	OK	OK	OK	OK	OK	OK		
6			3-2, Arithmetically. Separation?	59.170	62.630	66.160	68.370	68.040	66.530	65.020	63.220	61.620	59.540	56.680	51.040			
7			1-2, Arithmetically. Separation?	35.020	35.230	37.470	36.050	35.960	32.850	30.640	27.940	23.420	17.380	12.000	6.640			
<b>Bands with &lt;6db background separation:</b>																		
<b>Subtract Background measurement:</b>																		
8	$L_{pr}$		Log 3-2 (RSS+BGD)-BGD=RSS	72.290	72.080	72.130	71.990	71.120	69.590	68.270	67.310	66.300	65.140	62.790	57.080			
9	$L_{pf}$		Log 1-2 (FAN+BGD)-BGD=FAN	48.139	44.679	43.439	39.669	39.039	35.908	33.886	32.023	28.080	22.900	17.827	11.619			
<b>Calculate Room Characteristic Ratio and 1/3-Oct. Fan Sound Power:</b>																		
10	$L_{wr}$		RSS CAL Calibration Data (Given)	76.15	76.07	76.25	76.26	76.09	75.59	74.95	74.15	73.77	73.37	72.28	68.34			
11	$L_{rcr}$		Arith. 10-8 (RSS pow-pres=RCR)	3.860	3.990	4.120	4.270	4.970	6.000	6.680	6.840	7.470	8.230	9.490	11.260			
12	$L_{wrf}$		Arith. 9+11 (FAN pres+RCR=pow)	51.999	48.669	47.559	43.939	44.009	41.908	40.566	38.863	35.550	31.130	27.317	22.879			
<b>Fan Pressure at Std Distance, in Std Environment:</b>																		
14	$K_{rd}$		Given, dB down @ 5 feet	-14.65	-14.65	-14.65	-14.65	-14.65	-14.65	-14.65	-14.65	-14.65	-14.65	-14.65	-14.65			
15	$L_p$		Arith. 13-14 (Fan Test Results)	37.349	34.019	32.909	29.289	29.359	27.258	25.916	24.213	20.900	16.480	12.667	8.229			
<b>Convert to single Sones Rating Number:</b>																		
16	$s$		Lookup sones for each band	1.128	0.941	0.934	0.750	0.825	0.748	0.725	0.683	0.545	0.374	0.247	0.006			
17	$S$		Add sones & weight for HVI Sone Rating:															
(Reference. Lookup table ref. column number.)																		
				15	16	17	18	19	20	21	22	23	24	25	26			

## Formulae Used In HVI Sound Test Spreadsheet

Part of spreadsheet dated 06-Oct-05

Line	Formula
	"Limits for Background Steadiness" are not protected
1 - 4	Data Input
5	=IF(ABS(F9-F11)<F6,"OK","NoTest")
6	=F10-F9
7	=F8-F9
..<6db	=IF((OR(F14<6,F15<6)=TRUE),F5," ")
8	=10*LOG10((10^(F10/10))-(10^(F9/10)))
9	=IF((F8-F9<=0),0.0000001,(10*LOG10((10^(F8/10))-(10^(F9/10)))))
10	Reference Sound Source Calibrated Sound Power
11	=F21-F18
12	=F22+F19
14	Given presentation constant: 14.65
15	=IF(F23>(ABS(F25)),F23+F25,0)
16	=IF((VLOOKUP(F26,'HVI Loudness Indices'!\$A\$4:\$AB\$78,F30))+((F26-INT(F26))/1)*((VLOOKUP((F26+1),'HVI Loudness Indices'!\$A\$4:\$AB\$78,F30))-(VLOOKUP(F26,'HVI Loudness Indices'!\$A\$4:\$AB\$78,F30))))<0,0,(VLOOKUP(F26,'HVI Loudness Indices'!\$A\$4:\$AB\$78,F30))+((F26-INT(F26))/1)*((VLOOKUP((F26+1),'HVI Loudness Indices'!\$A\$4:\$AB\$78,F30))-(VLOOKUP(F26,'HVI Loudness Indices'!\$A\$4:\$AB\$78,F30))))
17	=0.85*(MAX(E28:AB28))+(0.15*(SUM(E28:AB28)))

The preceding are images of the Excel spreadsheets found on the HVI Sone calculation spreadsheet CD, available from HVI Headquarters.

## APPENDIX II. HVI EQUAL LOUDNESS INDEX TABLE

The following pages show an image of the HVI equal loudness index table, taken from *ANSI S3.4*. Loudness indices were experimentally developed by numerous research subjects subjectively ranking the different frequencies and sound pressures using comparison. The research was done by the Harvard Psychoacoustic Laboratory.

The HVI Sone calculation spreadsheet looks up the calculated test subject sound pressure in each frequency band to find the corresponding loudness index (s). Sound pressure values on the table are in whole numbers and the calculation uses straight-line interpolation to find the loudness index for each frequency.

The *ANSI S3.4* table has been refined as appropriate for HVI use. Refinements are in italics and are described below.

Extension to zero sone index. The lowest value in each frequency column was extended to zero or beyond using the preceding five intervals. This is necessary because very quiet products might otherwise receive inappropriate zero indices. The calculation uses no negative index numbers; if interpolation yields a negative number, that number is taken as zero.

Anomalies. Anomalies in the linearity of the table were found and adjusted to linear values in five cells. The cells are identified on page 2 of the table.



Page 2 of the HVI Equal Loudness Index Table

39		0.02	0.12	0.21	0.31	0.43	0.55	0.63	0.86	1.02	1.10	1.18	1.27	1.35	1.44	1.54	1.64	1.75	1.87	1.99	2.11	2.24	2.38	2.53	2.68	2.84	3.00	3.11	3.31	3.51	3.71	3.96	4.21	4.46	4.71	5.06	5.36	5.66	6.02	6.42	6.82	7.22	7.62	8.07	8.57	9.07	9.63	10.20	10.80	11.50	12.20	13.10	14.00	15.00	16.00	17.00	18.00	19.00	20.00																																																																																																																																																																																																	
40	-0.03	0.07	0.16	0.26	0.37	0.49	0.62	0.77	0.94	1.10	1.18	1.27	1.35	1.44	1.54	1.64	1.75	1.87	1.99	2.11	2.24	2.38	2.53	2.68	2.84	3.00	3.11	3.31	3.51	3.71	3.96	4.21	4.46	4.71	5.06	5.36	5.66	6.02	6.42	6.82	7.22	7.62	8.07	8.57	9.07	9.63	10.20	10.80	11.50	12.20	13.10	14.00	15.00	16.00	17.00	18.00	19.00	20.00																																																																																																																																																																																																		
41	0.02	0.12	0.21	0.31	0.43	0.55	0.69	0.86	1.04	1.18	1.27	1.35	1.44	1.54	1.64	1.75	1.87	1.99	2.11	2.24	2.38	2.53	2.68	2.84	3.00	3.11	3.31	3.51	3.71	3.96	4.21	4.46	4.71	5.06	5.36	5.66	6.02	6.42	6.82	7.22	7.62	8.07	8.57	9.07	9.63	10.20	10.80	11.50	12.20	13.10	14.00	15.00	16.00	17.00	18.00	19.00	20.00																																																																																																																																																																																																			
42	-0.03	0.07	0.16	0.26	0.37	0.49	0.62	0.77	0.94	1.13	1.27	1.35	1.44	1.54	1.64	1.75	1.87	1.99	2.11	2.24	2.38	2.53	2.68	2.84	3.00	3.11	3.31	3.51	3.71	3.96	4.21	4.46	4.71	5.06	5.36	5.66	6.02	6.42	6.82	7.22	7.62	8.07	8.57	9.07	9.63	10.20	10.80	11.50	12.20	13.10	14.00	15.00	16.00	17.00	18.00	19.00	20.00																																																																																																																																																																																																			
43	0.02	0.12	0.21	0.31	0.43	0.55	0.69	0.86	1.04	1.23	1.35	1.44	1.54	1.64	1.75	1.87	1.99	2.11	2.24	2.38	2.53	2.68	2.84	3.00	3.11	3.31	3.51	3.71	3.96	4.21	4.46	4.71	5.06	5.36	5.66	6.02	6.42	6.82	7.22	7.62	8.07	8.57	9.07	9.63	10.20	10.80	11.50	12.20	13.10	14.00	15.00	16.00	17.00	18.00	19.00	20.00																																																																																																																																																																																																				
44	0.07	0.16	0.26	0.37	0.49	0.62	0.77	0.94	1.13	1.33	1.44	1.54	1.64	1.75	1.87	1.99	2.11	2.24	2.38	2.53	2.68	2.84	3.00	3.11	3.31	3.51	3.71	3.96	4.21	4.46	4.71	5.06	5.36	5.66	6.02	6.42	6.82	7.22	7.62	8.07	8.57	9.07	9.63	10.20	10.80	11.50	12.20	13.10	14.00	15.00	16.00	17.00	18.00	19.00	20.00																																																																																																																																																																																																					
45	0.12	0.21	0.31	0.43	0.55	0.69	0.86	1.04	1.23	1.44	1.54	1.64	1.75	1.87	1.99	2.11	2.24	2.38	2.53	2.68	2.84	3.00	3.11	3.31	3.51	3.71	3.96	4.21	4.46	4.71	5.06	5.36	5.66	6.02	6.42	6.82	7.22	7.62	8.07	8.57	9.07	9.63	10.20	10.80	11.50	12.20	13.10	14.00	15.00	16.00	17.00	18.00	19.00	20.00																																																																																																																																																																																																						
46	0.16	0.26	0.37	0.49	0.62	0.77	0.94	1.13	1.33	1.54	1.64	1.75	1.87	1.99	2.11	2.24	2.38	2.53	2.68	2.84	3.00	3.11	3.31	3.51	3.71	3.96	4.21	4.46	4.71	5.06	5.36	5.66	6.02	6.42	6.82	7.22	7.62	8.07	8.57	9.07	9.63	10.20	10.80	11.50	12.20	13.10	14.00	15.00	16.00	17.00	18.00	19.00	20.00																																																																																																																																																																																																							
47	0.21	0.31	0.43	0.55	0.69	0.86	1.04	1.23	1.44	1.64	1.75	1.87	1.99	2.11	2.24	2.38	2.53	2.68	2.84	3.00	3.11	3.31	3.51	3.71	3.96	4.21	4.46	4.71	5.06	5.36	5.66	6.02	6.42	6.82	7.22	7.62	8.07	8.57	9.07	9.63	10.20	10.80	11.50	12.20	13.10	14.00	15.00	16.00	17.00	18.00	19.00	20.00																																																																																																																																																																																																								
48	0.26	0.37	0.49	0.62	0.77	0.94	1.13	1.33	1.56	1.75	1.87	1.99	2.11	2.24	2.38	2.53	2.68	2.84	3.00	3.11	3.31	3.51	3.71	3.96	4.21	4.46	4.71	5.06	5.36	5.66	6.02	6.42	6.82	7.22	7.62	8.07	8.57	9.07	9.63	10.20	10.80	11.50	12.20	13.10	14.00	15.00	16.00	17.00	18.00	19.00	20.00																																																																																																																																																																																																									
49	0.31	0.43	0.55	0.69	0.86	1.04	1.23	1.44	1.68	1.87	1.99	2.11	2.24	2.38	2.53	2.68	2.84	3.00	3.11	3.31	3.51	3.71	3.96	4.21	4.46	4.71	5.06	5.36	5.66	6.02	6.42	6.82	7.22	7.62	8.07	8.57	9.07	9.63	10.20	10.80	11.50	12.20	13.10	14.00	15.00	16.00	17.00	18.00	19.00	20.00																																																																																																																																																																																																										
50	0.37	0.49	0.62	0.77	0.94	1.13	1.33	1.56	1.82	1.99	2.11	2.24	2.38	2.53	2.68	2.84	3.00	3.11	3.31	3.51	3.71	3.96	4.21	4.46	4.71	5.06	5.36	5.66	6.02	6.42	6.82	7.22	7.62	8.07	8.57	9.07	9.63	10.20	10.80	11.50	12.20	13.10	14.00	15.00	16.00	17.00	18.00	19.00	20.00																																																																																																																																																																																																											
51	0.43	0.55	0.69	0.86	1.04	1.23	1.44	1.68	1.97	2.11	2.24	2.38	2.53	2.68	2.84	3.00	3.11	3.31	3.51	3.71	3.96	4.21	4.46	4.71	5.06	5.36	5.66	6.02	6.42	6.82	7.22	7.62	8.07	8.57	9.07	9.63	10.20	10.80	11.50	12.20	13.10	14.00	15.00	16.00	17.00	18.00	19.00	20.00																																																																																																																																																																																																												
52	0.49	0.62	0.77	0.94	1.13	1.33	1.56	1.82	2.11	2.24	2.38	2.53	2.68	2.84	3.00	3.11	3.31	3.51	3.71	3.96	4.21	4.46	4.71	5.06	5.36	5.66	6.02	6.42	6.82	7.22	7.62	8.07	8.57	9.07	9.63	10.20	10.80	11.50	12.20	13.10	14.00	15.00	16.00	17.00	18.00	19.00	20.00																																																																																																																																																																																																													
53	0.55	0.69	0.86	1.04	1.23	1.44	1.68	1.97	2.24	2.38	2.53	2.68	2.84	3.00	3.11	3.31	3.51	3.71	3.96	4.21	4.46	4.71	5.06	5.36	5.66	6.02	6.42	6.82	7.22	7.62	8.07	8.57	9.07	9.63	10.20	10.80	11.50	12.20	13.10	14.00	15.00	16.00	17.00	18.00	19.00	20.00																																																																																																																																																																																																														
54	0.62	0.77	0.94	1.13	1.33	1.56	1.82	2.11	2.38	2.53	2.68	2.84	3.00	3.11	3.31	3.51	3.71	3.96	4.21	4.46	4.71	5.06	5.36	5.66	6.02	6.42	6.82	7.22	7.62	8.07	8.57	9.07	9.63	10.20	10.80	11.50	12.20	13.10	14.00	15.00	16.00	17.00	18.00	19.00	20.00																																																																																																																																																																																																															
55	0.69	0.86	1.04	1.23	1.44	1.68	1.97	2.27	2.53	2.68	2.84	3.00	3.11	3.31	3.51	3.71	3.96	4.21	4.46	4.71	5.06	5.36	5.66	6.02	6.42	6.82	7.22	7.62	8.07	8.57	9.07	9.63	10.20	10.80	11.50	12.20	13.10	14.00	15.00	16.00	17.00	18.00	19.00	20.00																																																																																																																																																																																																																
56	0.77	0.94	1.13	1.33	1.56	1.82	2.11	2.44	2.68	2.84	3.00	3.11	3.31	3.51	3.71	3.96	4.21	4.46	4.71	5.06	5.36	5.66	6.02	6.42	6.82	7.22	7.62	8.07	8.57	9.07	9.63	10.20	10.80	11.50	12.20	13.10	14.00	15.00	16.00	17.00	18.00	19.00	20.00																																																																																																																																																																																																																	
57	0.86	1.04	1.23	1.44	1.68	1.97	2.27	2.62	2.84	3.00	3.11	3.31	3.51	3.71	3.96	4.21	4.46	4.71	5.06	5.36	5.66	6.02	6.42	6.82	7.22	7.62	8.07	8.57	9.07	9.63	10.20	10.80	11.50	12.20	13.10	14.00	15.00	16.00	17.00	18.00	19.00	20.00																																																																																																																																																																																																																		
58	0.94	1.13	1.33	1.56	1.82	2.11	2.44	2.81	3.00	3.11	3.31	3.51	3.71	3.96	4.21	4.46	4.71	5.06	5.36	5.66	6.02	6.42	6.82	7.22	7.62	8.07	8.57	9.07	9.63	10.20	10.80	11.50	12.20	13.10	14.00	15.00	16.00	17.00	18.00	19.00	20.00																																																																																																																																																																																																																			
59	1.04	1.23	1.44	1.68	1.97	2.27	2.62	3.00	3.20	3.40	3.60	3.80	4.10	4.30	4.60	4.90	5.20	5.50	5.80	6.20	6.60	7.00	7.40	7.80	8.30	8.80	9.30	9.90	10.50	11.10	11.80	12.60	13.50	14.40	15.30	16.40	17.50	18.70	19.90	21.10	22.40	23.80	25.30	26.80	28.40	30.00	31.70	33.50	35.30	37.20	39.20	41.30	43.50	45.80	48.20	50.70	53.30	56.00	58.80	61.70	64.70	67.80	71.00	74.30	77.70	81.20	84.80	88.50	92.30	96.20	100.20	104.30	108.50	112.80	117.20	121.70	126.30	131.00	135.80	140.70	145.70	150.80	156.00	161.30	166.70	172.20	177.80	183.50	189.30	195.20	201.20	207.30	213.50	219.80	226.20	232.70	239.30	246.00	252.80	259.70	266.70	273.80	281.00	288.30	295.70	303.20	310.80	318.50	326.30	334.20	342.20	350.30	358.50	366.80	375.20	383.70	392.30	401.00	409.80	418.70	427.70	436.80	446.00	455.30	464.70	474.20	483.80	493.50	503.30	513.20	523.20	533.30	543.50	553.80	564.20	574.70	585.30	596.00	606.80	617.70	628.70	639.80	651.00	662.30	673.70	685.20	696.80	708.50	720.30	732.20	744.20	756.30	768.50	780.80	793.20	805.70	818.30	831.00	843.80	856.70	869.70	882.80	896.00	909.30	922.70	936.20	949.80	963.50	977.30	991.20	1005.20	1019.30	1033.50	1047.80	1062.20	1076.70	1091.30	1106.00	1120.80	1135.70	1150.70	1165.80	1181.00	1196.30	1211.70	1227.20	1242.80	1258.50	1274.30	1290.20	1306.20	1322.30	1338.50	1354.80	1371.20	1387.70	1404.30	1421.00	1437.80	1454.70	1471.70	1488.80	1506.00	1523.30	1540.70	1558.20	1575.80	1593.50	1611.30	1629.20	1647.20	1665.30	1683.50	1701.80	1720.20	1738.70	1757.30	1776.00	1794.80	1813.70	1832.70	1851.80	1871.00	1890.30	1909.70	1929.20	1948.80	1968.50	1988.30	2008.20	2028.20	2048.30	2068.50	2088.80	2109.20	2129.70	2150.30	2171.00	2191.80	2212.70	2233.70	2254.80	2276.00	2297.30	2318.70	2340.20	2361.80	2383.50	2405.30	2427.20	2449.20	2471

## **APPENDIX III. EXPLANATION AND DISCUSSION – HVI FAN LOUDNESS TESTING AND RATING**

The outstanding benefits and strengths of HVI Certification require explanation in ordinary terms to provide a better understanding of them. This piece addresses the reasons HVI loudness certification is an outstanding program.

HVI Certification relies on ANSI consensus standards. HVI adds specific test procedures, designates a third-party laboratory, provides consistent calculations, oversees laboratory integrity, and certifies loudness ratings that recognize human psychoacoustic response.

Using those loudness ratings, HVI operates a comprehensive sound certification program that includes independent verification by HVI and the opportunity for competitors to challenge. The result is a full-featured loudness certification program.

Consistent ratings make it easy for designers and consumers to compare the loudness of HVI-Certified products and to be confident people will hear the products in the same relationship when installed. Because of its thoroughness and quality, HVI certification is recognized in codes and standards throughout North America, as well as most green-building programs.

### **Challenges of Rating Fan Loudness and HVI Solutions**

Rating residential ventilation equipment involves several challenges, technical and non-technical. The greatest challenges are described below, along with HVI's solutions.

First, measuring fan sound output is a difficult technical challenge because each fan has its own distinctive configuration that creates its sound signature. The measurement method must accommodate different motors, impellers, air paths, and numerous other differences.

For example, each fan's grille is uniquely styled. The shape of the grille determines how sound is ejected from the inside of the fan back into the room. Some fans 'squirt' sound out through holes in the grille. Other fans use a grille with a solid bottom panel to block direct exit of sound and force it to travel a circuitous path, losing some of its power on the way. Using a light analogy to visualize the variety of sound patterns emanating from different fans, imagine a light bulb inside the fan housing, producing shafts of light and areas of shadow. Thus, the sound field around each fan is different.

Any attempt to measure the total sound output of a fan in a free field would require measuring the output in every increment of an imaginary sphere around it and somehow totalizing the values—an impractical and inaccurate approach. HVI solves the challenge by measuring sound using the comparison method in a diffuse reverberation chamber.

Second, the sound of ventilation products must be rated so that people who hear the products will rank the products' loudness in the same order as the ratings, but that is not directly available from sound test instruments. One aspect is that humans relate differently to various frequencies. When people compare two equal-pressure sounds with different frequencies, the higher frequency will sound louder—except at very high frequencies. Sound ratings must be in terms of human perception of the loudness of the frequencies to be believable. HVI solves that challenge by using equal-loudness indices for each frequency band.

The other aspect of human response is that people are sensitive to dominant tones. 'White noise', an equal-loudness mixture of frequencies, sounds less loud (and less objectionable) than a spectrum that has one tone louder than the rest; the more dominant the frequency, the more people notice that tone. HVI solves that challenge by assigning the dominant tone much more weight than the rest of the bands.

Third, the rating must be simple so it is useful to millions of users without training. Professionals ordinarily use decibels, but they are a logarithmic measure and do not provide sound loudness numbers that seem logical to most people. Acousticians need several sound numbers for their calculations when designing a facility. However, people choosing a fan need a single-number rating to compare fans in catalogs or stores. HVI solves that challenge by rating loudness in single-number sones, which, unlike decibels, are linear to the human response.

Fourth, there must be third-party enforcement because people cannot intuitively see loudness, and they have no opportunity to measure sound. Even if people tried to measure, unpredictable factors related to the installation and environment would usually affect the sound level in the room more than the ventilation product would. HVI solves that challenge by an annual independent product performance verification program and a challenge procedure whereby competitors can challenge the ratings of another HVI Member's product.

### **Overview of the HVI Procedure**

HVI certification is a process with several steps, carefully designed to address the challenges described above. Before a detailed review of each step, an overview of the sequence is helpful.

- First, the ventilation product (fan) is tested for airflow in order to establish the HVI-Certified airflow rating point, which is then used as the sound rating point.
- Without modification or intervention, that same test unit is transferred to the sound test chamber, where its sound power is determined in 24 frequency bands.
- The sound power of the fan is converted to sound pressure (which is what people hear).

- The sound pressure is converted to equal loudness indices in all 24 bands, reflecting human sensitivity loudness at various frequencies.
- The 24 equal loudness indices are summed into a single value, with the loudest frequency weighted for human sensitivity to dominant tones.

## Step-by-Step Description and Discussion

### Airflow Test is a Prerequisite for Sound Test

HVI sound testing is conducted at the HVI airflow certification conditions, including airflow, nominal static pressure and revolutions per minute. This provides a standardized basis for comparing performance of HVI-Certified ventilation equipment.

### The Sound Test Chamber

Sound for HVI ratings is measured using the comparison method in an HVI-designated test laboratory equipped with a diffuse reverberation chamber constructed in accordance with *ANSI S12.51*.

The reverberation chamber ‘homogenizes’ the fan’s shafts and shadows of sound by allowing the sound waves to reflect around inside the chamber. Using a light analogy, the chamber may be likened to a room with mirrors on all six surfaces, turning a point light source into a uniformly lit room.

Ordinarily the reverberating sound would tend to establish a persistent three-dimensional network of standing waves. However, the chamber is called a ‘diffuse’ reverberation chamber because it employs measures to break up the patterns of the sound reflections, randomizing them. The walls are non-parallel, creating random reflection and minimizing the standing waves. Stationary corner baffles, carefully positioned using room qualification techniques, further interrupt standing waves to create a reasonably diffuse sound field. Once more using the light analogy, the sound inside the chamber is similar to the uniform scattering of light in a dense fog—it is difficult to identify the location of the light source.

Anything inside the chamber that could cause variations between tests, including baffles, equipment used for sound testing, and the test subject are always placed in the same marked location.

The chamber is equipped for realistic sound testing of ventilation equipment, which requires there be airflow at the same rate as the airflow rating. The chamber has a sound-insulated air intake and exhaust. The intake is an insulated low velocity duct with sound interrupting turns. It is also equipped with a quiet variable speed boost blower that can be used for higher flow rates, and an insulated intake throttle damper. The exhaust is through an insulated duct connected to the chamber with a flexible anti-vibration collar. The exhaust duct discharges into a large anechoic muffler with a throttling damper where it finally exhausts into the general laboratory environment.

Thus, air can flow through the chamber with minimal sound transmission, and flow resistance (static pressure) can be adjusted to airflow rating conditions.

### **The Reference Sound Source**

The Reference Sound Source (RSS) is the ‘gold standard’ for the comparison method. It conforms to *ANSI S12.5*, which requires it to project sound uniformly in all directions, leaving minimal ‘sound shadows’. Its sound power signature is required to be within established decibel limits in each of the 24 one-third-octave bands for which it will be used.

Practically, the RSS is an instrument consisting of a synchronous motor (for consistent performance) with a special impellor to generate white noise. The RSS is calibrated annually in a qualified calibration laboratory that issues a report documenting the sound power in each band.

### **The Microphones**

The sound test microphones are key sound testing instruments. They are required to provide calibrated response to sound pressure over the spectrum tested. They must conform to *ANSI S1.15*, which specifies their response characteristics. The microphones are directly connected to a preamplifier that provides a signal of sufficient amplitude to eliminate cable sensitivity between the microphones and the sound analyzer.

#### Six Microphone Array Method

For averaging amplitude, six microphones are located in fixed locations qualified to average the sound pressure to counteract standing waves that may exist in the room, even after previously described preventive measures are in place.

#### Rotating Boom Method

For averaging amplitude, the microphone is mounted on a rotating boom that sweeps through a long arc that cuts across the maximum and minimum amplitudes of any standing waves that may exist in the room after previously described preventive measures are in place.

### **The Sound Analyzer**

The sound analyzer receives the signal from the microphones, averages it when the array is used, and divides it digitally into the 24 ANSI-prescribed one-third-octave bands with center frequencies from 50 to 10,000 hertz. It averages the measured amplitude over a prescribed period (30 seconds) and records the resulting 24 data points. Data are then transferred electronically to the calculating and report-producing program.

### **Measurements in the Sound Test Chamber**

Conducting the actual test is strictly in accordance with *HVI Publication 915*©. The test unit is mounted as specified by the appropriate diagram and the test subject is run to warm the motor to operating temperature. Chamber pressure is adjusted to establish fan speed (rpm) to that recorded at nominal pressure during the airflow test, thus ensuring the sound test is conducted at the same set of conditions as the certified airflow rating.

Once the fan is warm and the chamber is adjusted to the required static pressure, the first sound pressure measurements are taken and saved electronically; this is the fan plus background. In sequence, as quickly as practical, three more measurements are conducted. The first is background with nothing operating. The second is reference sound source plus background. The last is background, measured the second time for the background steadiness check.

### **Background Steadiness and Quietness**

HVI requires a steady background during a test. As part of the test, the background is measured twice, and the two measurements of the background must be within established limits for each of the 24 bands. If not, the background is considered to have changed excessively during the test, which renders the test ineffective and it must be repeated.

HVI requires a quiet background for testing. Reasons for a quiet background are obvious, but the degree of background separation and the methods for dealing with insufficiently quiet background vary between other organizations that control sound testing. Review of publications from various sources indicates a wide variety of background separation requirements, varying from 3 dB, 6 dB, 10 dB, and even 15 dB, although 6 dB is the most common.

Instructions for action when background is insufficiently quiet also vary, although typical procedures require that the background be reduced and the test re-done. It is not always possible to lower the background 6 decibels below the test unit, especially with quiet test subjects, so various organizations have established methods of dealing with that condition. One method, unacceptable to HVI, is to simply take fan sound pressure as zero, based on the rationale that testing with less than 6 decibels is not practical. For example, if a fan plus background measures 7 decibels and a background measures 5 decibels, this method takes the fan as 0 decibels. While that assumption may have been defensible when bands were measured one by one, and values were visually averaged, today's real-time simultaneous measurement and averaging make it impossible to justify.

Another method, also unacceptable to HVI, is to subtract the background as if it is 6 decibels, whenever it is less than 6 decibels below the fan plus background. To be precise, the method calls for arithmetically deducting 1.3 from the test measurement to yield fan sound pressure. This method results in higher fan sound pressure than

measured. For example, if a fan plus background measures 7 decibels and a background measures 5 decibels, this method takes the fan as 5.7 decibels. HVI finds no logical support for that approach.

HVI continues to require background to be 6 decibels lower than the fan plus background, and calls for the background to be reduced and the test re-run. When that is not possible, HVI enters a footnote on each band with less than 6 decibels, and uses the measured values for the calculations. With HVI's method, for example, if a fan plus background measures 7 decibels and a background measures 5 decibels, fan pressure is calculated to be 2.67 decibels. While it is always possible to debate methods, the HVI approach is, at least, logical.

Having satisfied background steadiness and quietness, the test is considered complete and the data recorded during the test are digitally transferred to the calculation procedure.

### Calculations for Sound Power

First, the background sound pressure is subtracted logarithmically from the measured sound pressure of fan plus background, and RSS plus background, yielding the fan sound pressure and RSS sound pressure resulting from the chamber measurements.

Then the comparison method uses the sound pressure measurements to establish sound power. The sound pressure of a source is proportional to the sound power of that source, both measured in decibels. Reference Sound Source sound power is known through calibration. The sound pressure developed in the chamber by a known sound power source, to the sound pressure developed in the chamber by the unknown (test) source to find its sound power. The concept can be defined as mathematical ratios. (Symbols are defined in *HVI Publication 915*®, and values are in decibels— $L$  is sound,  $w$  is power, and  $p$  is pressure.)

$$\frac{L_{wr}}{L_{pr}} = \frac{L_{wf}}{L_{pf}}$$

In practice, the calculation is accomplished as follows:

$$L_{wf} = \left( \frac{L_{wr}}{L_{pr}} \right) L_{pf}$$

The ratio of the known sound power of the RSS, and the measured sound pressure of the RSS, HVI calls the room characteristic ratio (RCR) because it depicts the character of the sound chamber. The ratio is the RSS calibrated sound power divided by the RSS sound pressure, and since both are in logarithmic dB, the ratio is found by subtracting.

Fan sound power is then found by comparison. The fan sound pressure is multiplied by the RCR, and since it is logarithmic, the process used is add-on. The result is the fan sound power, which is the amount of electrical energy the fan converts to sound power.

### **Calculations for Sound Pressure**

Once fan sound power is known, it is necessary to present it in practical terms. People hear sound pressure, the result of sound power, at a distance, in a certain environment. HVI standard sound pressure is at five feet in a spherical free field. Those results in the adopted constant 14.65, the quantity deducted from the fan sound power to determine the fan sound pressure at the presentation distance and condition. Sound power in each of the 24 one-third-octave bands is converted to the sound pressure the fan will produce in each band.

### **Equal Loudness Indices**

HVI now refers to the table in ANSI S3.4 to find the loudness index that corresponds to the fan sound pressure in each of the 24 one-third-octave bands.

### **Weighting the Dominant Frequency – the Sone Rating**

Before summing the 24 equal loudness indices into a single sone number, the loudest of the 24 is identified. Then, in accordance with *ANSI S3.4*, the dominant (loudest) band is given full value and the sum of the other 23 is taken at 15 percent value (multiply times 0.15). Practically, that results in the index of the dominant tone being given about 6.7 times more weight than any of the other loudness indices. The sum is the sone rating, the value used when submitting the application to HVI for the certified rating of the product.

### **ANSI S3.4**

*ANSI S3.4* is the result of work done by Dr. S. S. Stevens while he was head of the Harvard Psychoacoustic Laboratory. While there he conducted extensive acoustic research, testing numerous human subjects for their perception of equal loudness. Dr. Stevens published a progression of articles as understanding of the human response to acoustical stimulation evolved.

The work that eventually became *ANSI S3.4* was first published in the Journal of the Acoustic Society of America, November, 1961, as Stevens' Mark VI sones. It is considered to be the pinnacle of Dr. Stevens' work for rating sounds of the type produced by residential ventilation equipment.

Subsequent work by Dr. Stevens (e.g. Mark VII sones) and work by others was studied by HVI in 1999 and 2000 by HVI for possible adoption, or perhaps modification of methods then being used. Some of the alternatives provided rating more appropriate for louder sounds and/or sounds with more impact, and others provided insights into human hearing response for use in hearing aids. None, however, offered improvements over the basic *ANSI S3.4* method for rating ventilation equipment, and HVI decided to continue using it.

*ANSI S3.4* was originally published by ASA following the publication of Dr. Stevens' Mark VI article, previously described. The current version was released in 1980, and most recently reaffirmed in 2003. Hence the full designation: *ANSI S3.4-1980 (R 2003)*.

As an outgrowth of studying various loudness rating methodologies, in 2005 HVI adopted more stringent calculation requirements and prescribed the method of dealing with less than 6 decibels background separation described above.

### **HVI Verification and Challenge**

HVI's Verification Program requires HVI Headquarters to annually procure products in the marketplace without the member's involvement, and deliver them to an HVI-designated laboratory for testing. Products that fail to meet their rating are considered probationary and if not rectified within a time limit, certification is withdrawn. HVI reports the results of its annual verification testing to the membership (without violating confidentiality) so the membership may assess the strength of the program.

HVI's Challenge Program permits any company to challenge the ratings of another company's product. Under the challenge, HVI procures products in the marketplace without the member's involvement and delivers them to an HVI-designated laboratory for testing. Products that fail to meet their rating are considered probationary and if not rectified within a time limit, certification is withdrawn. HVI assesses the cost of the challenge to the loser—the challenger if the product passes, and the challengee if it fails.

These programs are considered by HVI to be an essential element of certification, for without them or something similar, there can be no enforcement.

### **Limitations of HVI Certification**

The HVI certification program is practical, technically solid, and provides ratings that are particularly valuable for comparing catalog rated performance of residential ventilation equipment. The airflow ratings and sound ratings have great value as nominal product ratings, but installation variations can have a tremendous effect on final performance, sometimes dominating the installed results.

For airflow, duct system characteristics affect performance. Duct material, type, size, fittings and installation quality all have an effect which neither the fan manufacturer nor HVI can possibly control.

Fan loudness is also affected by the installation. Whether a room tends to absorb or reflect sound and the solidness of the installation are examples of factors that neither the fan manufacturer nor HVI can control.

### **Summary**

The HVI sound certification program compares very favorably to any other program for comparing product sound, and stands out as superior in most cases.